

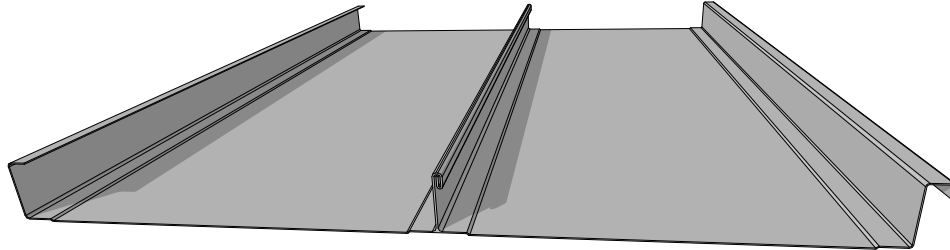

MECHANICAL LOCK STANDING SEAM



Warranty:

Painted steel is covered by a 35 or 40 year limited warranty. To see warranty details for S.M.P click [HERE](#). For P.V.D.F warranty details click [HERE](#). Some exclusions may apply.

Specs:

- 14" - 16" Coverage
- 1.5" - 2" Seam Height
- 26ga, 24ga, 22ga, (Grade 50)
- Minimum recommended roof slope 2:12 or 1/2:12 w/Sealant with a 2" SS profile
- Solar reflectivity index : varies per color
- Concealed fastener
- Requires mechanical seaming of panels
- Striations or minor ribs recommended
- Requires clips
- Available as pre-notched panel with a 1.5" SS profile

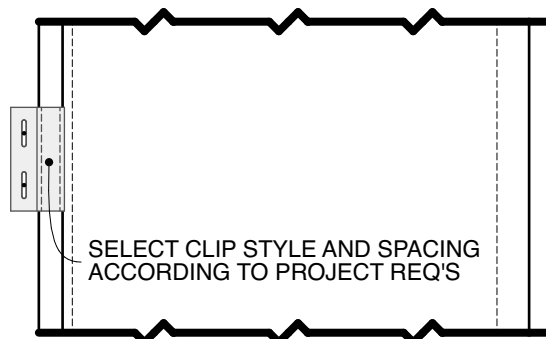
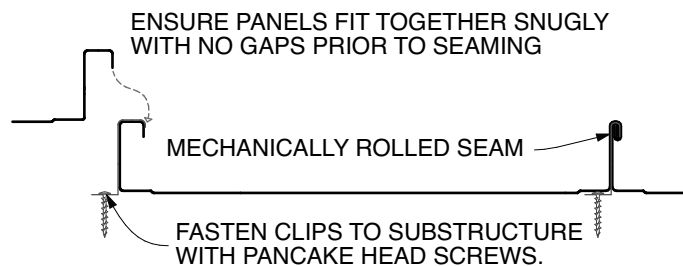



SAFETY

Metal roofs can become extremely slippery due to dust, moisture, frost, oil, etc. Wear slip-resistant shoes and monitor changing conditions throughout the project.

Exercise caution when working at height and use appropriate fall protection measures. Always stay aware of your position on the roof in relation to co-workers, roof edges, skylights, and other hazards.

Metal panels & trim conduct electricity. Use extreme caution when working near power lines or electrical supply.

Do not walk on metal.

Metal sheets are heavy and unwieldy. Do not attempt to install in windy conditions.

Metal edges are sharp. Cutting metal can produce sharp filings. Wear gloves and eye protection.

STORAGE

Projects should be coordinated and scheduled to minimize storage time and potential damage. Materials should be kept dry and out of harm's way. Store apart from corrosive or contaminating substances such as fuel, oil, acid, cleaners, paint, etc.

If storing outside:

1. Isolate from ground moisture with plastic sheet
2. Support sheets at intervals to avoid sagging
3. Elevate bundles to allow air circulation
4. Slope bundles lengthwise for drainage
5. Shelter with a loose tarp to allow air circulation
6. Do not store outside for more than 4 weeks

Prolonged moisture exposure while stacked will damage the finish. Damage from improper storage is not covered by warranty.

HANDLING

Bundled panels and trim are heavy. Provide sufficient manpower.

Trim and panels should be carried edgeways (not flat) and handled in a way that avoids bending, kinking or distorting the profile. Long panels and trim may require multiple people to handle properly.

Metal ribs and trim should not be stepped on at any time.



COMMON TRIMS

| | | | | |
|-------------------------------------|--------------------------------------|---|--|---|
| RIDGE CAP ID: 01B | CLEATED VALLEY ID: 02C | CLEATED PITCH BREAK ID: 04G | ENDWALL OPEN HEM ID: 50B | SIDEWALL OPEN HEM ID: 50C |
| ARCH'L EAVE ID: 07B | FASCIA ID: 106R | COLOR GUARD ID: 62 | Z-TRIM ID: 20 | ARCH'L GABLE ID: 22 |
| PEAK FLASHING ID: 31D | OFFSET CLEAT ID: 26 | CLEAT ID: 26B | Z TRIM ID: 20D | ARCH'L RAKE/GABLE ID: 22D |

Additional standard and custom profiles available for order

INSTALLATION

Install flashing from the bottom up. Make sure that all laps face downward for drainage and channel water away/out from the structure. Do not rely entirely upon sealant!

Do not use abrasive blades to cut (grinder cut-off wheels and such like). The heat produced will burn the finish causing rust and discoloration.

Clean up all filings and scraps from the surface. These can leave rust spots.

Use approved high temperature underlayment

Mechanical Lock requires clips for hold-down, select clip style and spacing according to projects requirements.

Clips are commonly placed at intervals of 16 inches, subject to the specific needs of the project.

Mechanical lock standing seam is designed to accommodate the expansion and contraction of steel panels.

Galvanized metal will expand / contract by as much as 1/8" per 16' for every 100 degree change in temperature.

Ensure there is adequate room for expansion or contraction of the panels as project requires

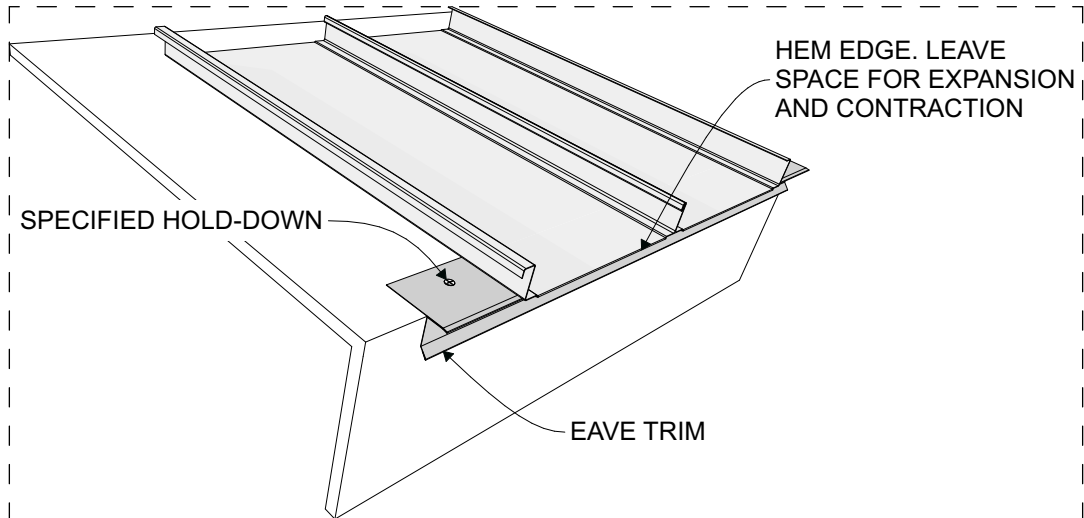
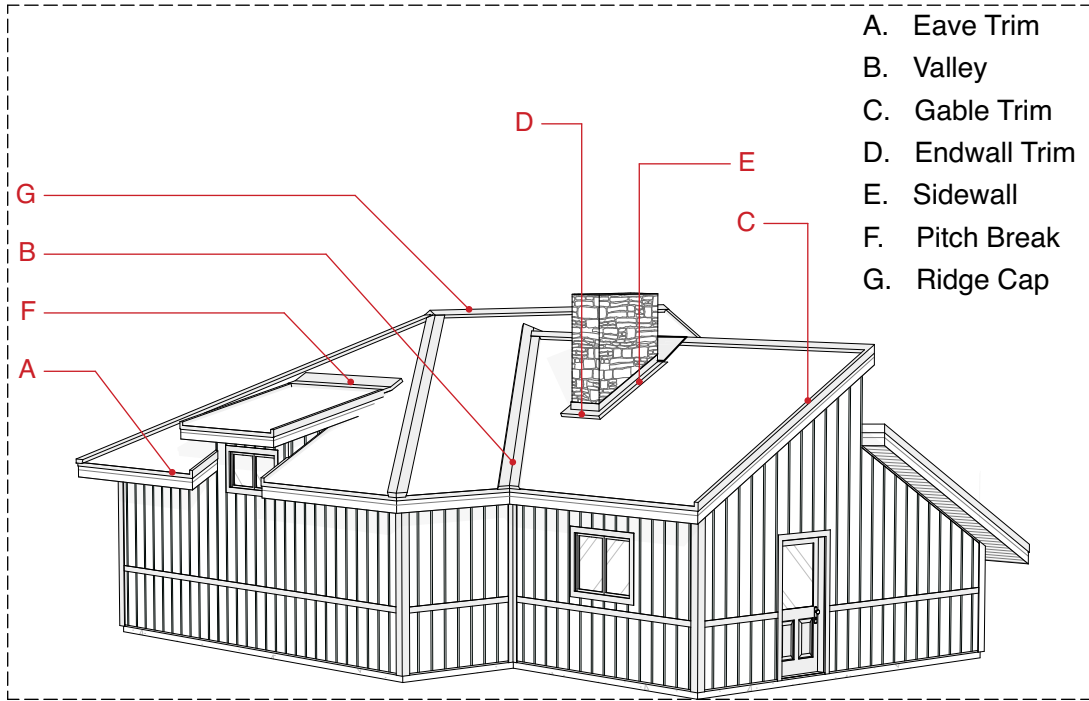

A | EAVE TRIM

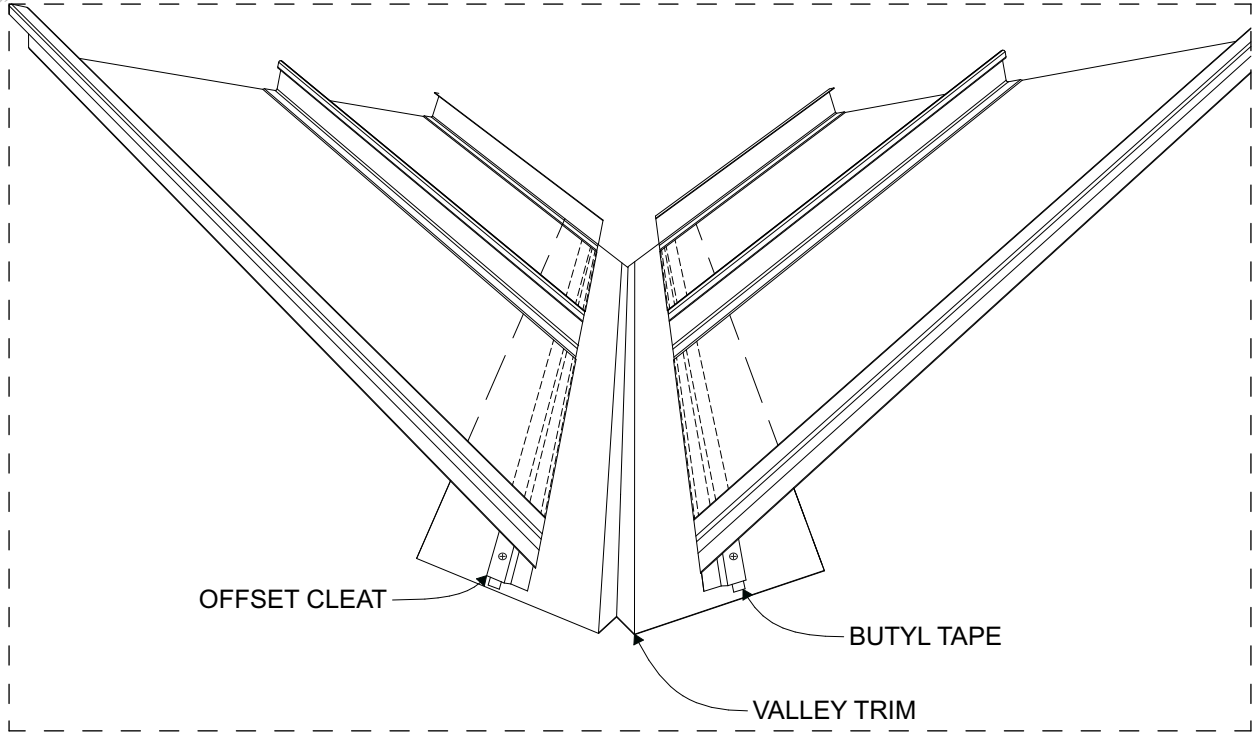

B | VALLEY

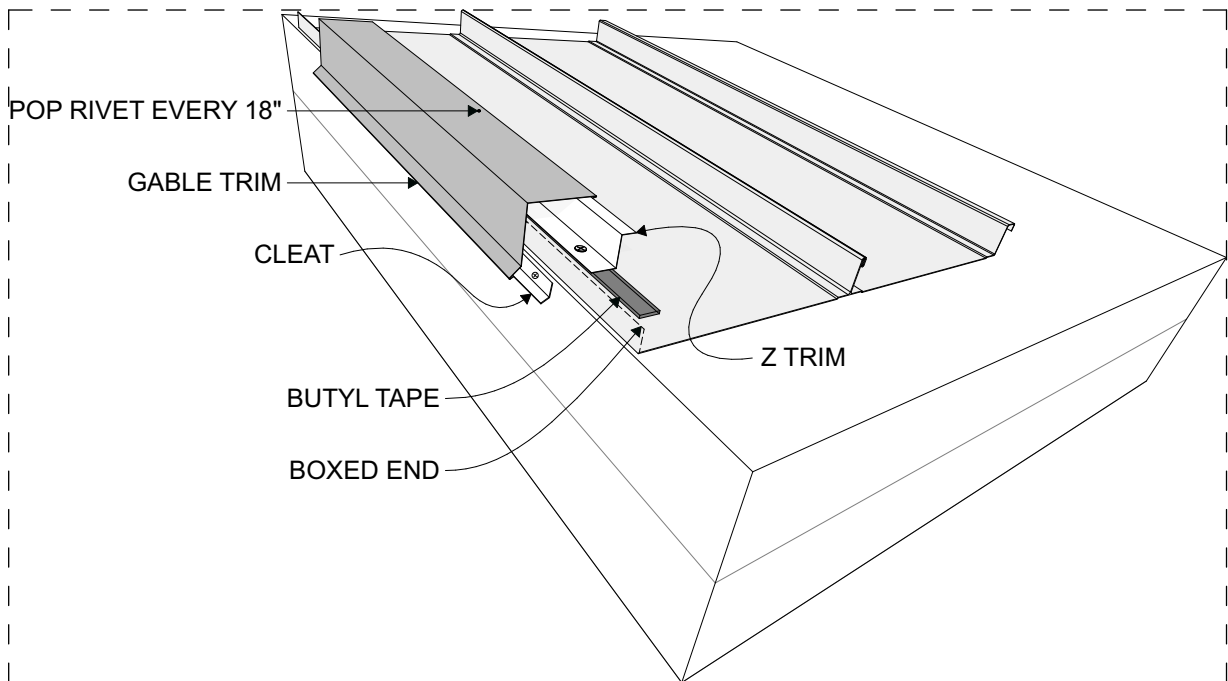

C | GABLE TRIM

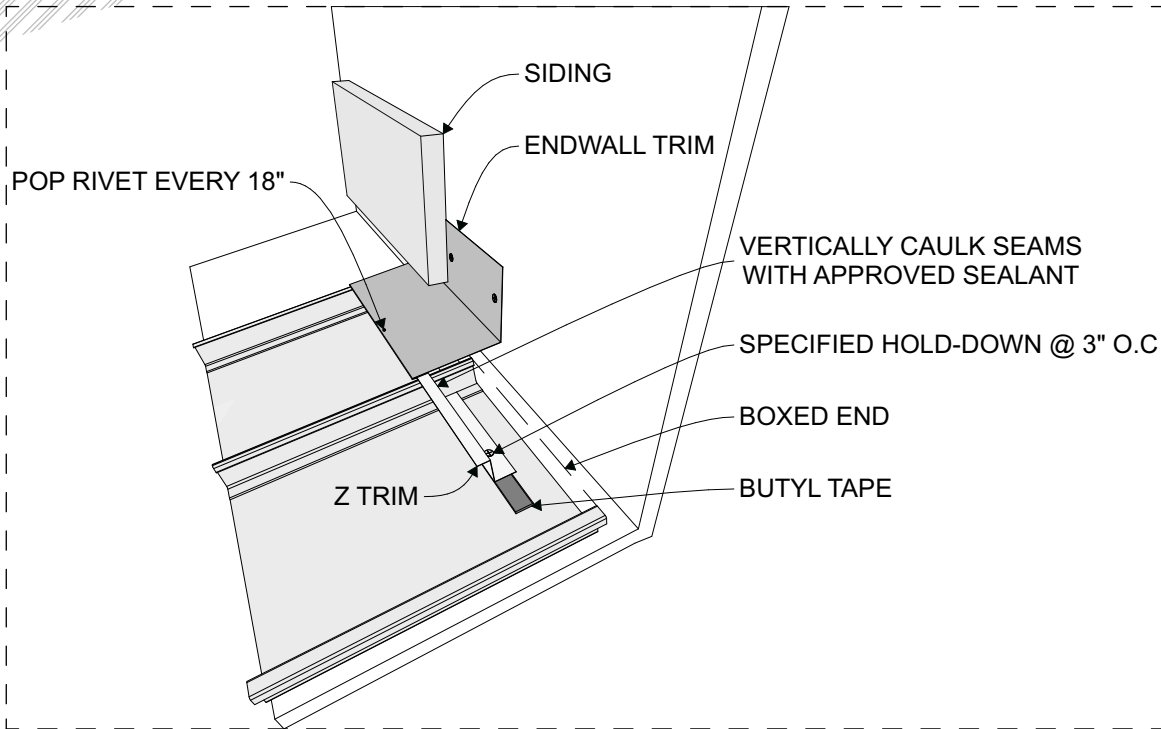

D | ENDWALL TRIM

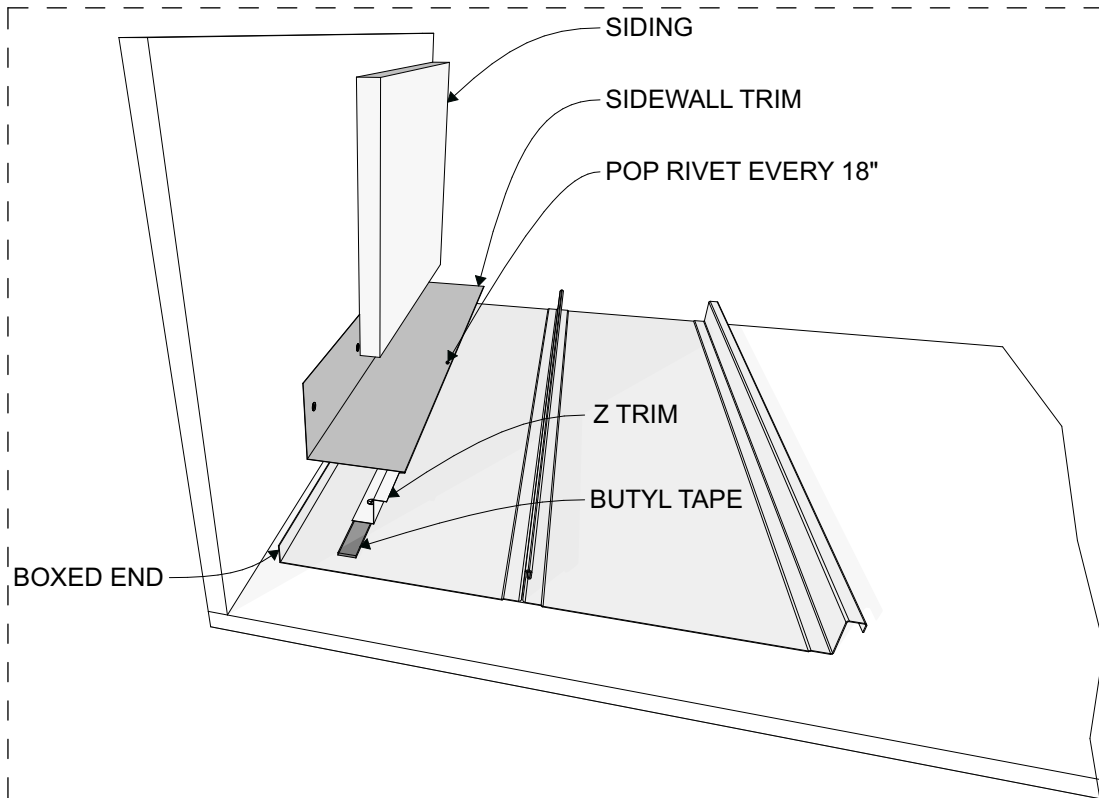

E | SIDEWALL TRIM

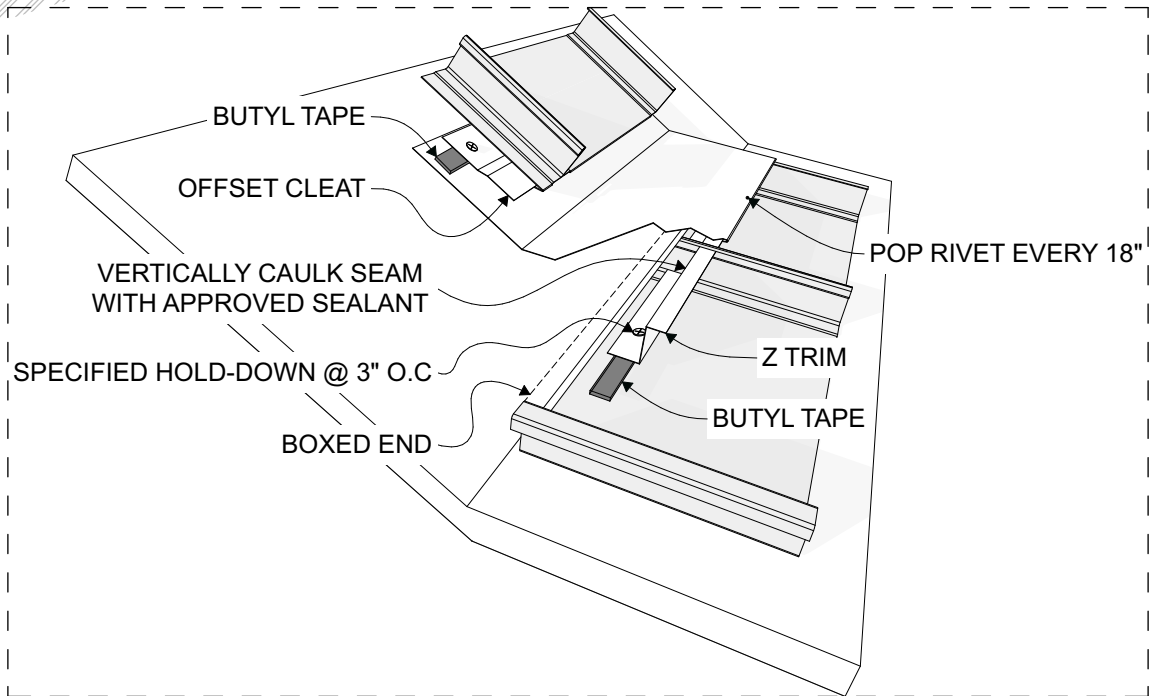

F | PITCH BREAK

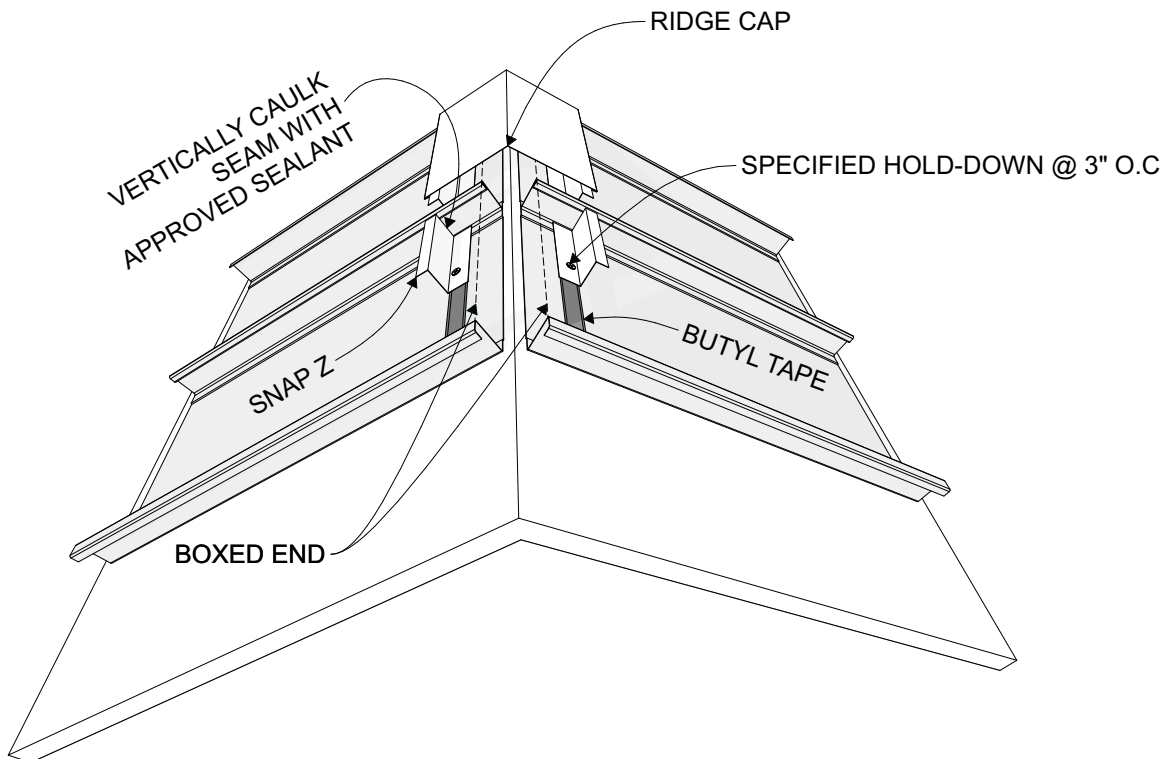

G | RIDGE CAP

